

PRELIMINARY



VSX.4

VSX Displays

KEY FEATURES

- Designed and built to operate perfectly in harsh working conditions
- Important data of a machine can be visualized in many different ways
- Flexible mounting variants
- The connection to the control system is realized with field bus systems
- Intuitive programming via the graphical interface of the development kit

TECHNICAL DATA

- Available in 8" and 12"
- ZU4EV - Cortex A53 QuadCore 1.3 GHz
- Display brightness up to 1300 cd/m², viewing angle up to ±80°
- up to 4 CAN interfaces, 5x 100 Mbit/s ethernet
- 4 analog camera inputs (PAL/NTSC), 2 displayable in parallel

ACCESSORIES

- VSX starter kit
- Ethernet cable
- USB to M12 cable
- Mating plug set Superseal, 26 pin

Sensor-Technik Wiedemann GmbH

Am Bärenwald 6
87600 Kaufbeuren

+49 8341 9505-0
info.stw@wiedemann-group.com
www.stw-mm.com

BLOCK DIAGRAM

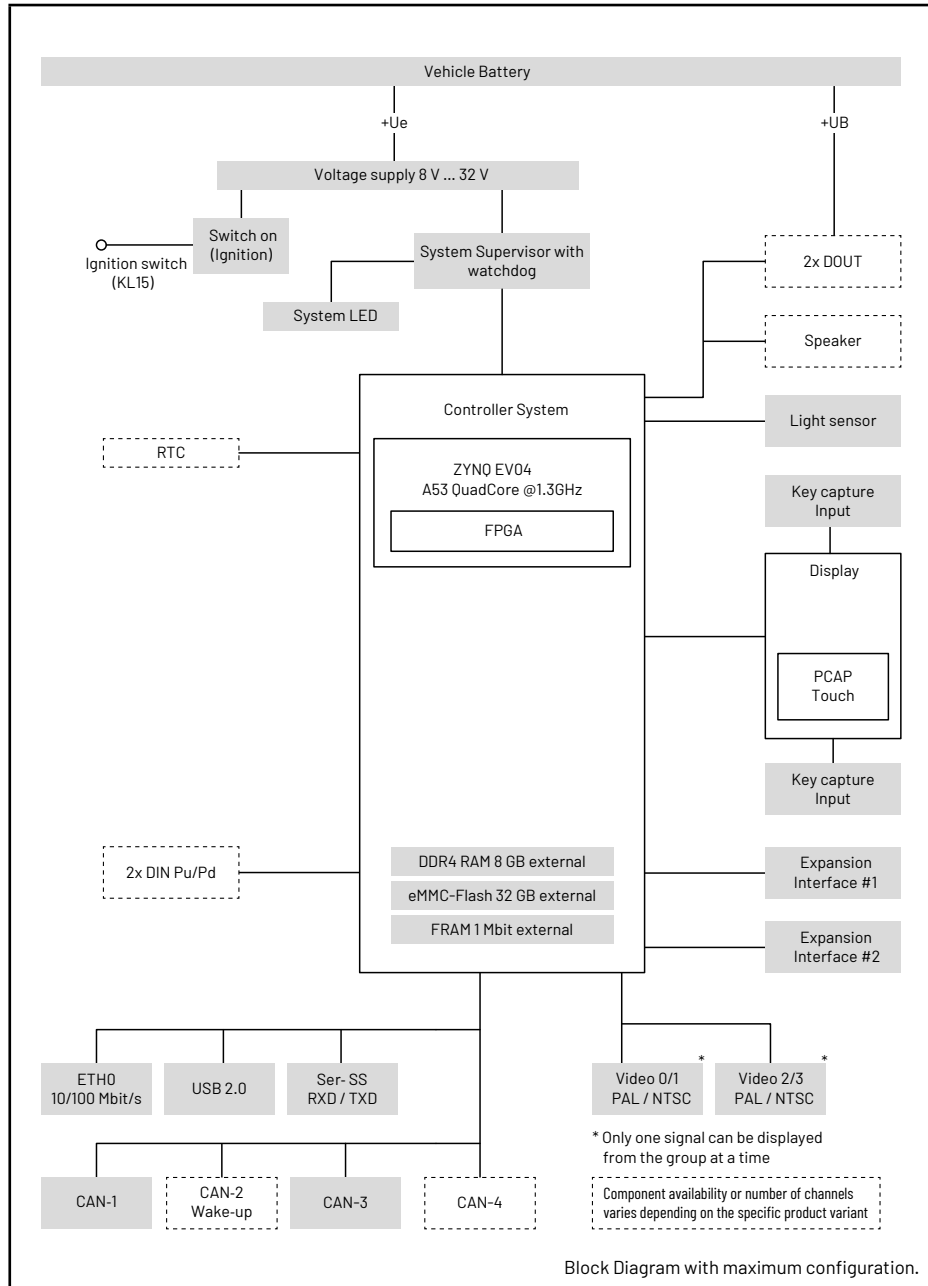

TECHNICAL DATA

Processor and memory

Processor	ZU4EV - Cortex A53 QuadCore 1.3 GHz
RAM	2 GB DDR4, 64 Bit
eMMC-Flash	32 GB
FRAM	1 Mbit

Configuration

Type	106113	106114	106115
Screen size	8.4"	8.4"	12.1"
Aspect ratio	4:3	4:3	4:3
Brightness	1000 cd/m ²	1000 cd/m ²	1300 cd/m ²
Contrast	600:1	600:1	800:1
Resolution	1024 x 768	1024 x 768	1024 x 768
Viewing Angles	H ±80° V +80°/-60°	H ±80° V +80°/-60°	H ±80° V ±80°
Glass finish	3H without touch	3H without touch	3H without touch
Mean time to half brightness	100.000 h	100.000 h	100.000 h
Mounting method	Back mount	Back mount	Panel mount
RTC	Gold cap buffered additionally over Ue	—	—

TECHNICAL DATA

Communication interfaces

Type	106113	106114	106115
Ethernet 1	10/100 Mbit/s	10/100 Mbit/s	10/100 Mbit/s
Ethernet 2-5	4x 100Mbit/s	4x 100Mbit/s	4x 100Mbit/s
CAN 1	Without galvanic isolation	Without galvanic isolation	Without galvanic isolation
CAN 2	CAN WakeUp	–	–
CAN 3	Without galvanic isolation	Without galvanic isolation	Without galvanic isolation
CAN 4	Without galvanic isolation	–	–
USB Host	1x USB 2.0	–	–
Analog video in 1, 2 (PAL/NTSC)	1 out of 2 displayable	1 out of 2 displayable	1 out of 2 displayable
Analog video in 3, 4 (PAL/NTSC)	1 out of 2 displayable	1 out of 2 displayable	1 out of 2 displayable

Inputs (only available with item number 106113)

Type	Quantity	Possible configuration	Measurement
DIN	2	Digital	NPN/PNP

Outputs (only available with item number 106113)

Type	Quantity	Possible configuration	Characteristics
DOUT	2	Digital	ON/OFF

Miscellaneous

Streaming Ethernet Video	H.264 Hardware accelerated 4x4 CIF (Softwareoption)
OpenGL graphical effects and 3D	OpenGL ES 1.1 GPU Hardware acceleration (Softwareoption)
Temperature	-30 °C ... +70 °C

TECHNICAL DRAWING

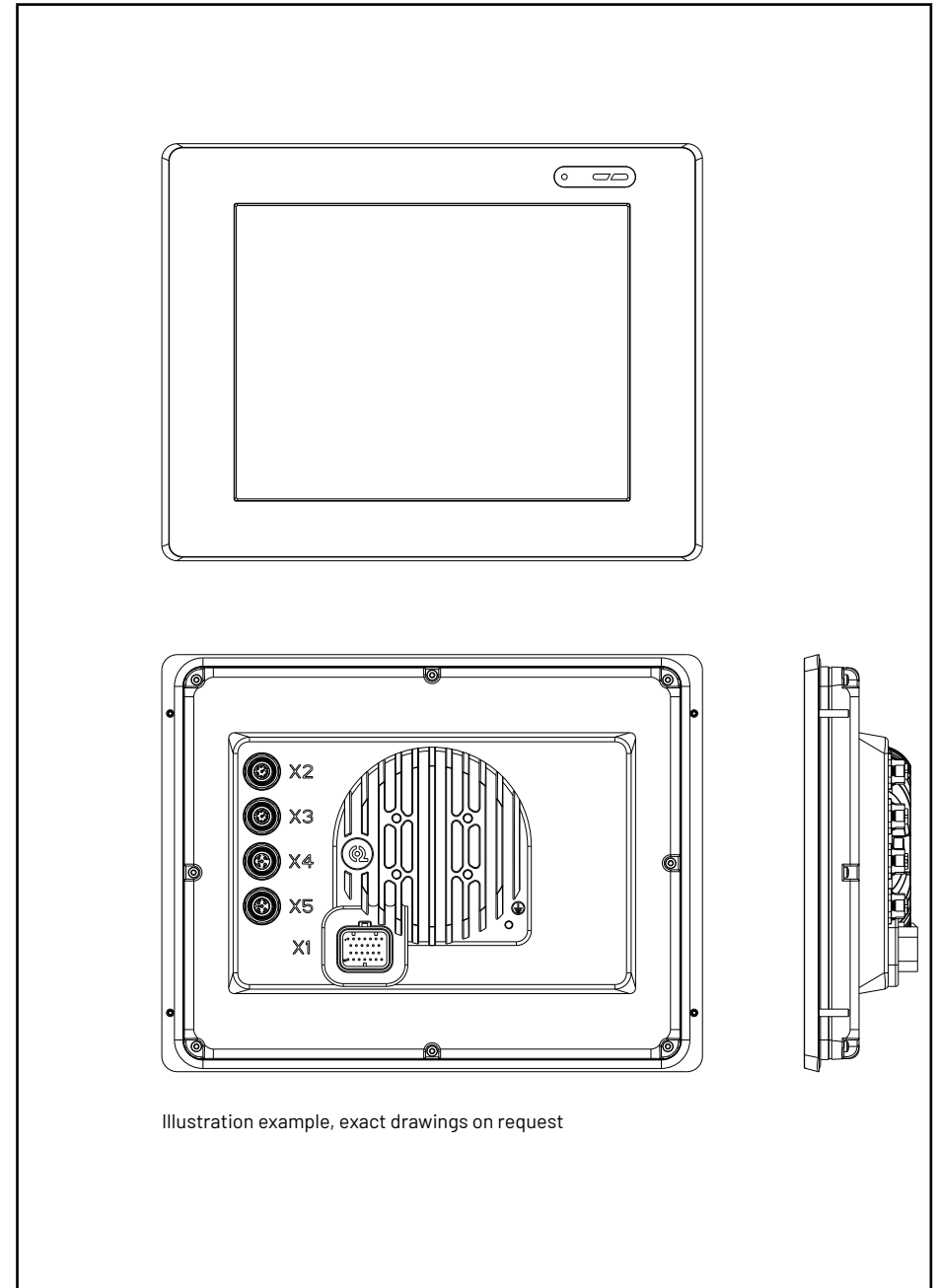

PIN ASSIGNMENT VSX.4

Pin assignment of connector X1 sorted by pin numbers

X1 Pin	Signal description	X1 Pin	Signal description
1	DIN1	14	—
2	—	15	DOUT2
3	DOUT1_0V	16	Supply voltage KL15+
4	Supply voltage UBAT+	17	CAN 2 low
5	CAN 1 high	18	CAN 4 low
6	CAN 3 high	19	—
7	External lithium battery ¹⁾ for real time clock (RTC), battery minus (-)	20	DIN2
8	—	21	—
9	DOUT1	22	DOUT2_0V
10	Supply voltage UE+	23	Supply voltage UBAT- GND for digital inputs
11	CAN 1 low	24	CAN 2 high
12	CAN 3 low	25	CAN 4 high
13	External lithium battery ¹⁾ for real time clock (RTC), battery plus (+)	26	—

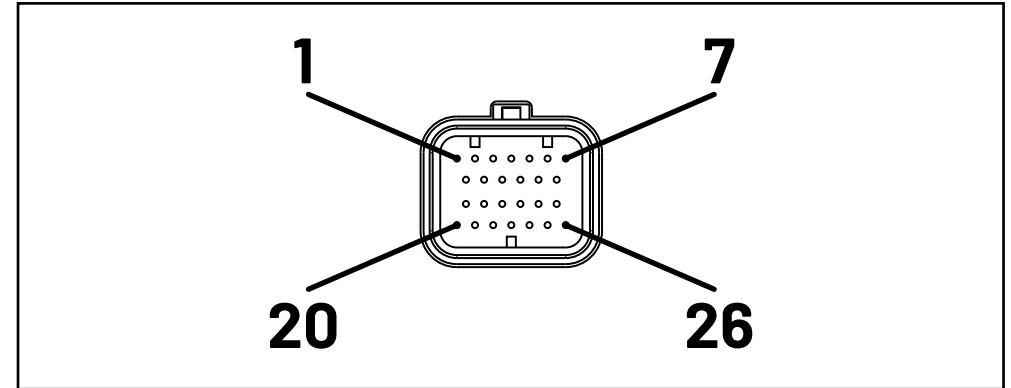

Pin assignment of connector X2 sorted by pin numbers

X2 Pin	Signal description
1	Analog Video In 1: Signal GND
2	Analog Video In 1: Signal +
3	Analog Video In 1: 12 V output (250 mA)
4	Analog Video In 1: 12 V output GND
5	Analog Video In 2: 12 V output GND
6	Analog Video In 2: Signal GND
7	Analog Video In 2: Signal +
8	Analog Video In 2: 12 V output (250 mA)
Housing	Outer conductor (shield)

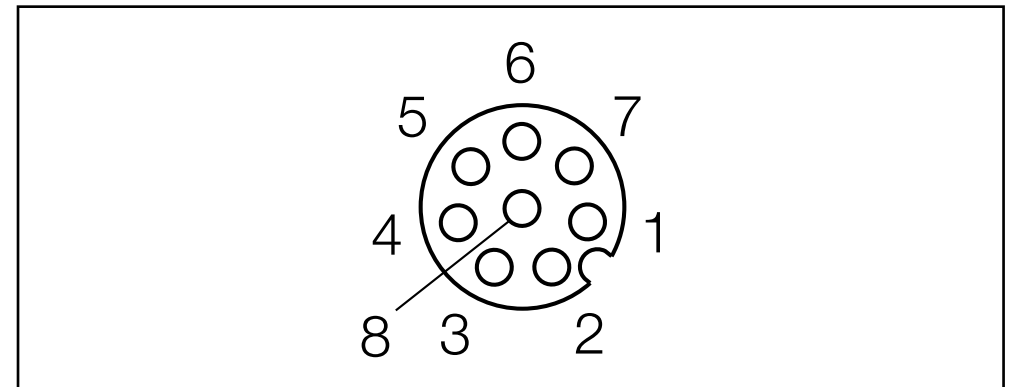

¹⁾ Li-SOCI2, 1/2AA, 3,6 V, 1200 mAh

PIN ASSIGNMENT VSX.4

Pin assignment of connector X3 sorted by pin numbers

X3 Pin	Signal description
--------	--------------------

1	Analog Video In 3: Signal GND
2	Analog Video In 3: Signal +
3	Analog Video In 3: 12 V output (250 mA)
4	Analog Video In 3: 12 V output GND
5	Analog Video In 4: 12 V output GND
6	Analog Video In 4: Signal GND
7	Analog Video In 4: Signal +
8	Analog Video In 4: 12 V output (250 mA)
Housing	Outer conductor (shield)

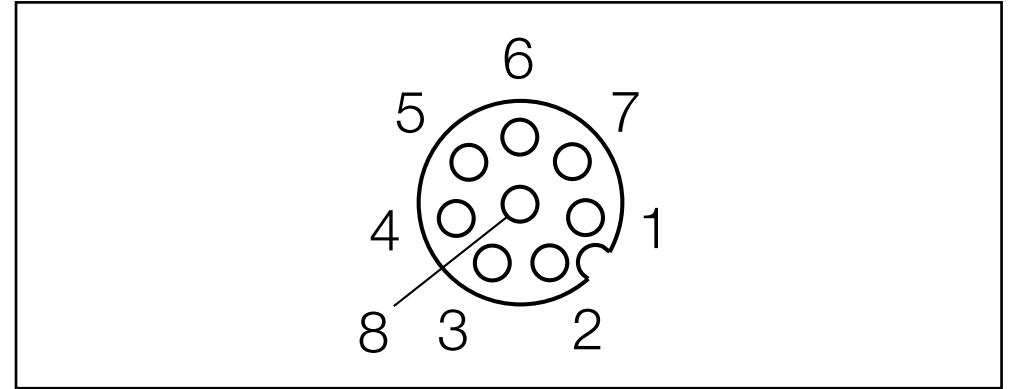

Pin assignment of connector X4 sorted by pin numbers

X4 Pin	Signal description
--------	--------------------

1	TXp
2	RXp
3	TXn
4	RXn
Housing	Ethernet outer conductor (shield)

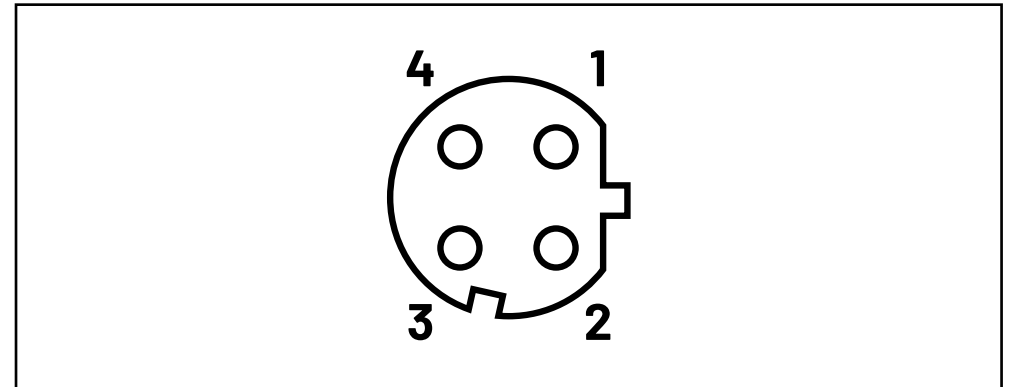

PIN ASSIGNMENT VSX.4

Pin assignment of connector X5 sorted by pin numbers

X5 Pin	Signal description
--------	--------------------

1	5 V at 500 mA
2	USB-Dn
3	USB-Dp
4	Not Used
5	GND
Housing	Ethernet outer conductor (shield)

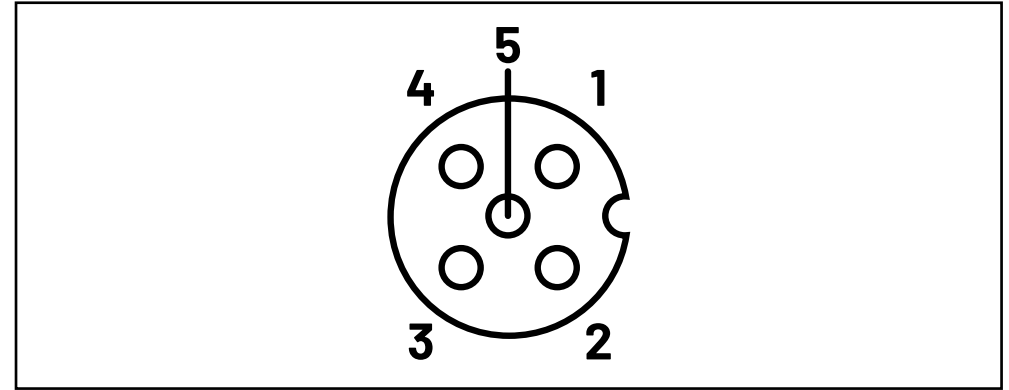

Pin assignment of connector X6 sorted by pin numbers

X6 Pin	Signal description
--------	--------------------

1	TXp
2	RXp
3	TXn
4	RXn
Housing	Ethernet outer conductor (shield)

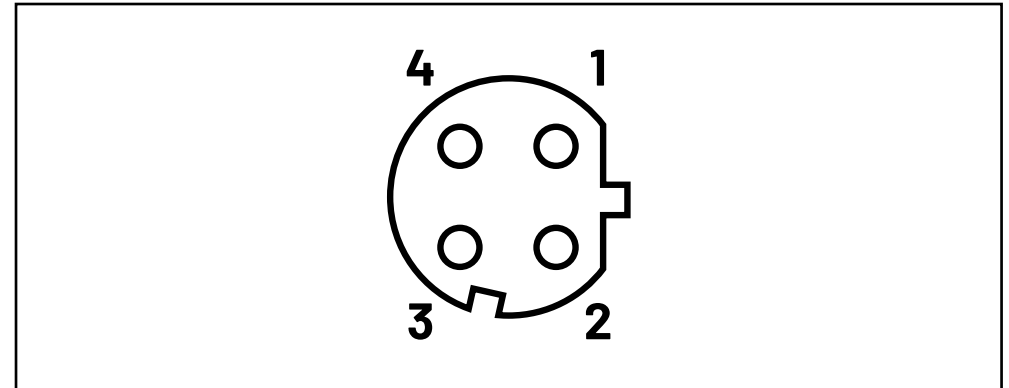

PIN ASSIGNMENT VSX.4

Pin assignment of connector X7 sorted by pin numbers

X7 Pin	Signal description
--------	--------------------

1	TXp
2	RXp
3	TXn
4	RXn
Housing	Ethernet outer conductor (shield)

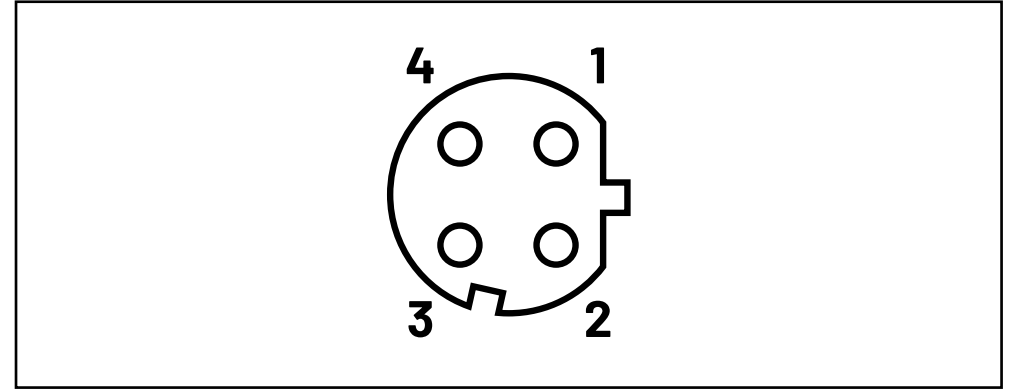

Pin assignment of connector X8 sorted by pin numbers

X8 Pin	Signal description
--------	--------------------

1	TXp
2	RXp
3	TXn
4	RXn
Housing	Ethernet outer conductor (shield)

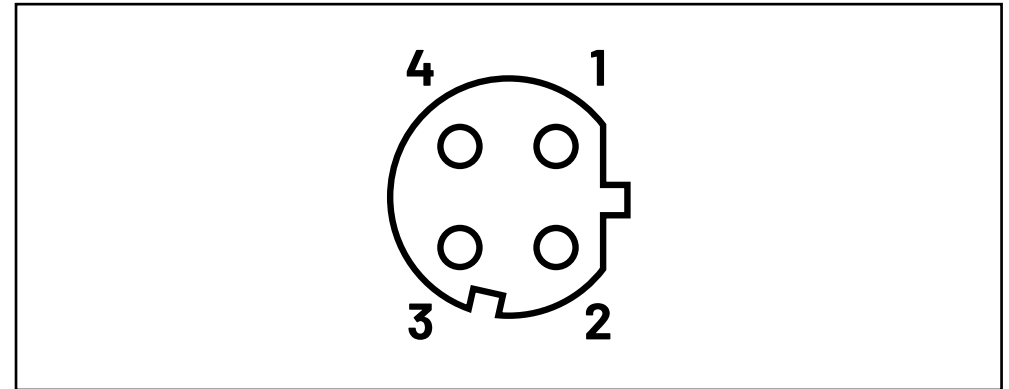

Pin assignment of connector X9 sorted by pin numbers

X9 Pin	Signal description
--------	--------------------

1	TXp
2	RXp
3	TXn
4	RXn
Housing	Ethernet outer conductor (shield)

